

robinet papillon

butterfly valve type 2610

RP 21055

03 / 01

double excentration
double offset

entre brides
wafer

PMA - WP
2.5 bar

DN 100 DN 1200

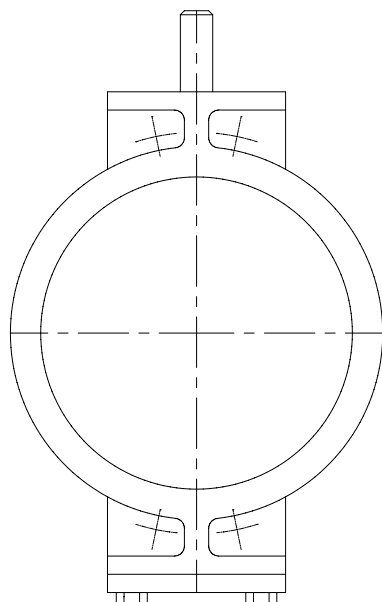

Conception:

Robinet papillon à double excentration, type entre brides

- DN 100 DN 600 siège démontable en élastomère fixé sur le corps
- DN 700 DN 1200 joint démontable en élastomère fixé sur l'obturateur
- 4 trous taraudés pour centrage (DN 450)

Design:

Double offset butterfly valve, wafer type

- DN 100 DN 600 removable rubber seat fitted in body
- DN 700 DN 1200 removable rubber seal ring fitted on the edge of the disc
- 4 threaded holes for centring (DN 450)

Montage entre brides - Etanchéité Fonte / Elastomère
Wafer type to fit between flanges - Rubber / Cast iron seating surface

Pression maximale admissible (PMA à 20°C) - *Maximum working pressure (WP 20°C)*

DN 100 DN 1200 : 2.5 bar

Essais :

Toute notre robinetterie subit un contrôle unitaire en nos ateliers suivant la norme ISO 5208:

- essai du siège = 1.1 x PMA
- essai du corps = 1.5 x PMA
- fluide d'essai: eau
- taux de fuite: A (100% étanche)

Sur demande :

- corps et/ou obturateur en FGS 500-7
- bague de maintien du siège ou du joint en inox
- montage entre brides répondant à d'autres normes

Tests :

Each valve is tested in our facilities according to ISO 5208 standard :

- seat = 1.1 x WP
- body = 1.5 x WP
- test carried out with water
- leak rate: A (100% water tight)

On request :

- body and/or disc in ductile iron GGG-50
- seal ring retainer in stainless steel
- fitting between flanges according to different standards



Vannes Lefebvre - Miroux

B.P. 45 - Avenue de Lassus - 59481 HAUBOURDIN cedex France

Tel : (33) 03 20 17 51 00 - Fax : (33) 03 20 17 51 01

<http://www.lefebvre.fr> - contact@lefebvre.fr

DN 100 DN 1200

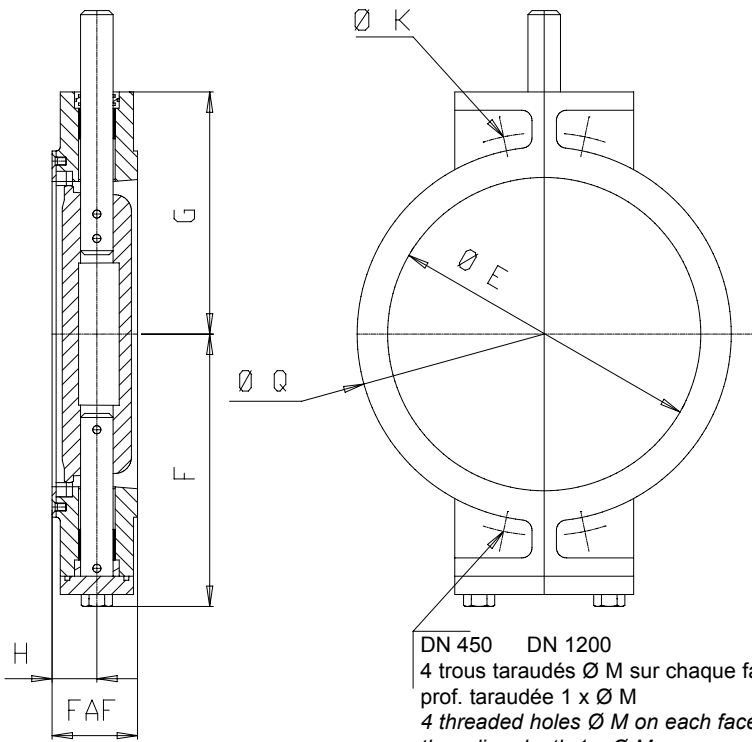

DN 450 DN 1200
4 trous taraudés Ø M sur chaque face
prof. taraudée 1 x Ø M
4 threaded holes Ø M on each face
threading depth 1 x Ø M

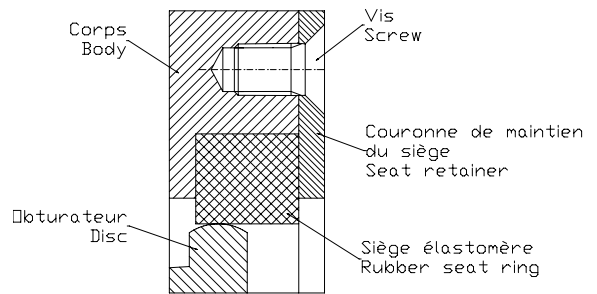

DN 100 DN 600

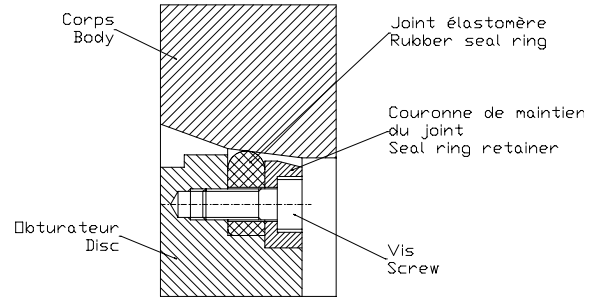

DN 700 DN 1200

Dimensions : (mm)

DN	100	125	150	200	250	300	350	400	450	500	600	700	800	900	1000	1200
Ø E	98	125	150	200	247	295	327	378	428	480	575	676	775	875	975	1175
FAF	60	68	74	78	84	90	98	106	119	131	154	165	190	203	216	254
F	143	153	170	218	249	288	312	349	374	409	520	570	630	655	715	815
G	120	130	147	185	216	255	273	310	335	370	475	525	585	645	705	865
H	32	36	39	41	44	47	51	55	61	67	79	83	95	102	108	127
Ø K									565	620	725	840	950	1050	1160	1380
Ø M									M24	M24	M27	M27	M30	M30	M33	M36
Ø Q	160	190	216	270	320	375	436	480	535	592	690	800	900	1005	1110	1330
Poids Weight	8.5 Kg	11.5 Kg	16 Kg	27 Kg	36 Kg	50 Kg	79 Kg	98 Kg	131 Kg	169 Kg	335 Kg	413 Kg	505 Kg	506 Kg	671 Kg	933 Kg

06/04/99

Matériaux - Materials :

	DN 100	DN 600	DN 700	DN 800	DN 900	DN 1200
Corps Body	FGL 250 Cast iron GG-25	FGL 250 Cast iron GG-25	FGL 250 Cast iron GG-25		FGS 500-7 Ductile iron GGG-50	
Obturateur Disc	FGL 250 Cast iron GG-25	FGL 250 Cast iron GG-25	FGL 250 Cast iron GG-25		FGS 500-7 Ductile iron GGG-50	
Arbre Shaft	Acier inox AISI 304 Stainless steel	Acier inox AISI 304 Stainless steel	Acier inox AISI 304 Stainless steel		Acier inox AISI 304 Stainless steel	
Siège rapporté de corps Body seat ring	Elastomère Rubber					
Siège rapporté d'obturateur Disc seat ring			Elastomère Rubber		Elastomère Rubber	
Coussinets Bearing	Autolubrifiant Self lubricating	Autolubrifiant Self lubricating	Autolubrifiant Self lubricating		Autolubrifiant Self lubricating	
Visserie intérieure Internal screw	Acier inox Stainless steel	Acier inox Stainless steel	Acier inox Stainless steel		Acier inox Stainless steel	
Visserie extérieure External screw	Acier Steel	Acier Steel	Acier Steel		Acier Steel	

Conditions de service :

Pression maximale admissible en fonction de la température de service.

t° service - working t°	PMA - WP
-10°C 120°C	2,5 bar

Service rating :

Maximum working pressure according to working temperature.