

vanne à membrane diaphragm valve

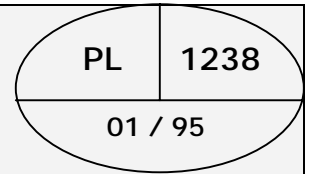

HYDRANE - TYPE 100 – 4TM1RV STANDARD

TETE PNEUMATIQUE NORMALEMENT FERMEE, CORPS A BRIDES PARALLELES
CLOSED ON AIR FAILURE HEAD, PARALLEL-FLANGED BODY

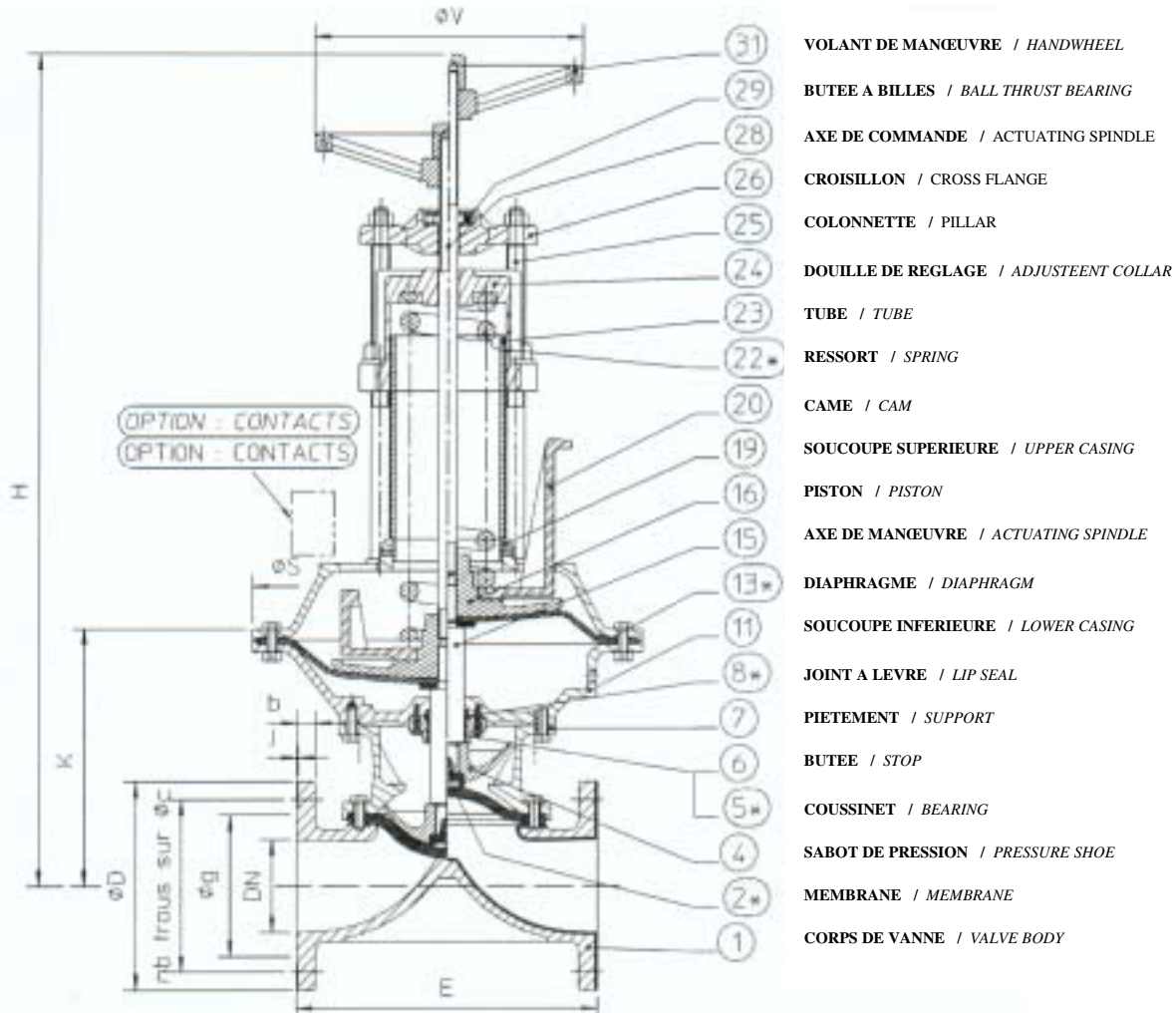

*Pièces de rechange de 1^{ère} nécessité / * spare parts of first necessity

VANNES A TETE PNEUMATIQUE ET CORPS STANDARD ECARTEMENT « NF » PNEUMATIC HEAD VALVE AND « NF » SPACING STANDARD BODY.

BRIDES PN10 / NP10 FLANGES

DN	100	125	150	200	250
D	220	250	285	340	395
g	158	188	212	268	320
j	3	3	3	3	3
b	20	22	24	26	28
c	180	210	240	295	350
Nb trous / nb holes	8	8	8	8	12
Ø trous / Ø holes	18	18	22	22	22

DN	100	125	150	200	250
E mm	350	400	480	600	650 ^(a)
H	910	925	1075	1480	1505
K	290	295	350	---	---
S	460	460	540	---	---
V	315	315	315	500	500
Poids / Weight (kg)	116	124	185	---	---

(a) NON-CONFORME A LA NORME NF E 29-492

(a) NOT IN COMPLIANCE WITH NORM NF E 29-492

BRIDES PN 16 OU ASA 125/150 SUR DEMANDE / NP16 OR ASA 125/150 FLANGES ON REQUEST



Vannes Lefebvre - Miroux
B.P.45 - Avenue de Lassus - 59481 HAUBOURDIN cedex France
Tel : (33) 03 20 17 51 00 - Fax : (33) 03 20 17 51 01
<http://www.lefebvre.fr> - contact@lefebvre.fr