

vanne à membrane

diaphragm valve

PL

1224

01 / 94

HYDRANE - TYPE 100-4TM2R STANDARD

TETE PNEUMATIQUE DOUBLE EFFET, CORPS A BRIDES PARALLELES / DOUBLE EFFECT HEAD, PARALLEL-FLANGED BODY

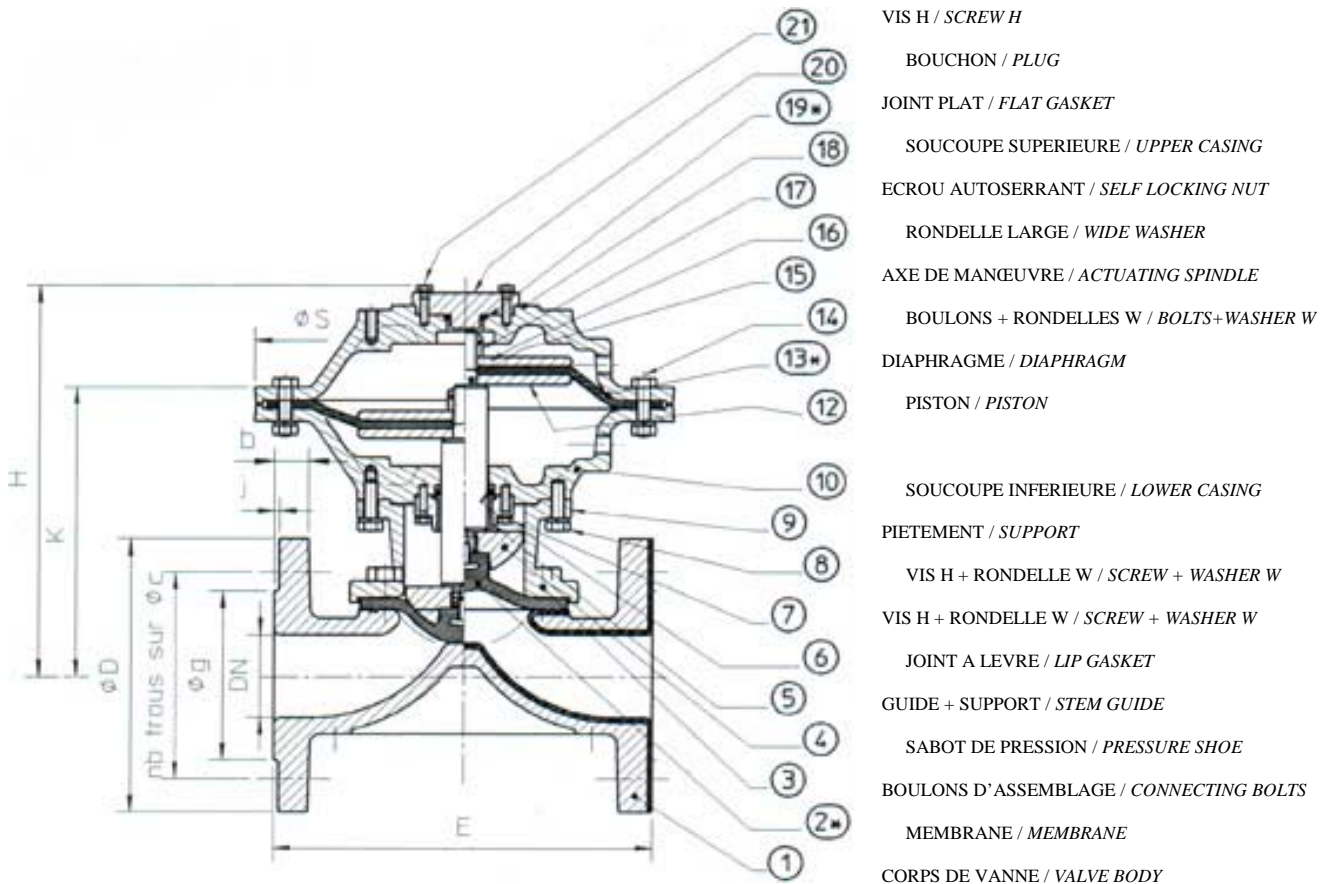

- 21 VIS H / SCREW H
- 20 BOUCHON / PLUG
- 19* JOINT PLAT / FLAT GASKET
- 18 SOUCOUPE SUPERIEURE / UPPER CASING
- 17 ECROU AUTOSERRANT / SELF LOCKING NUT
- 16 RONDELLE LARGE / WIDE WASHER
- 15 AXE DE MANCEUVRE / ACTUATING SPINDLE
- 14 BOULONS + RONDELLES W / BOLTS+WASHER W
- 13* DIAPHRAGME / DIAPHRAGM
- 12 PISTON / PISTON
- 10 SOUCOUPE INFERIEURE / LOWER CASING
- 9 PIETEMENT / SUPPORT
- 8 VIS H + RONDELLE W / SCREW + WASHER W
- 7 VIS H + RONDELLE W / SCREW + WASHER W
- 6 JOINT A LEVRE / LIP GASKET
- 5 GUIDE + SUPPORT / STEM GUIDE
- 4 SABOT DE PRESSION / PRESSURE SHOE
- 3 BOULONS D'ASSEMBLAGE / CONNECTING BOLTS
- 2* MEMBRANE / MEMBRANE
- 1 CORPS DE VANNE / VALVE BODY

* Pièces de 1^{ère} nécessité / * spare parts of first necessity

VANNES A TETE PNEUMATIQUE ET CORPS STANDARD ECARTEMENT « NF » PNEUMATIC HEAD VALVE AND « NF » SPACING STANDARD BODY.

BRIDES PN10 / NP10 FLANGED

DN	20	25	32	40	50	65	80	100	125	150
D	105	115	140	150	165	185	200	220	250	285
g	58	68	78	88	102	122	133	158	184	212
j	2	2	2	3	3	3	3	3	3	3
b	16	16	18	18	20	20	20	20	22	24
c	75	85	100	110	125	145	160	180	210	240
Nb trous	4	4	4	4	4	4	8	8	8	8
Ø trous	14	14	18	18	18	18	18	18	18	22
E mm	150	160	180	200	230	290	310	350	400	480
H	200	200	245	245	245	295	325	380	390	465
H1	220	220	220	220	220	295	295	320	320	445
K	130	135	165	170	175	235	240	290	295	350
S	200	200	260	260	260	400	400	460	460	540
V	150	150	150	150	150	200	200	250	250	300
Poids (Kg)	9	10	18	19	22	40	52	79	86	133

BRIDES PN 16 OU ASA 125/150 SUR
DEMANDE

NP 16 OR ASA 125/150 FLANGES ON
REQUEST



Vannes Lefebvre - Miroux

B.P.45 - Avenue de Lassus - 59481 HAUBOURDIN cedex France

Tel : (33) 03 20 17 51 00 - Fax : (33) 03 20 17 51 01

http://www.lefebvre.fr - contact@lefebvre.fr